

RIGHT ANGLE GEAR DRIVES

FOR COOLING TOWERS

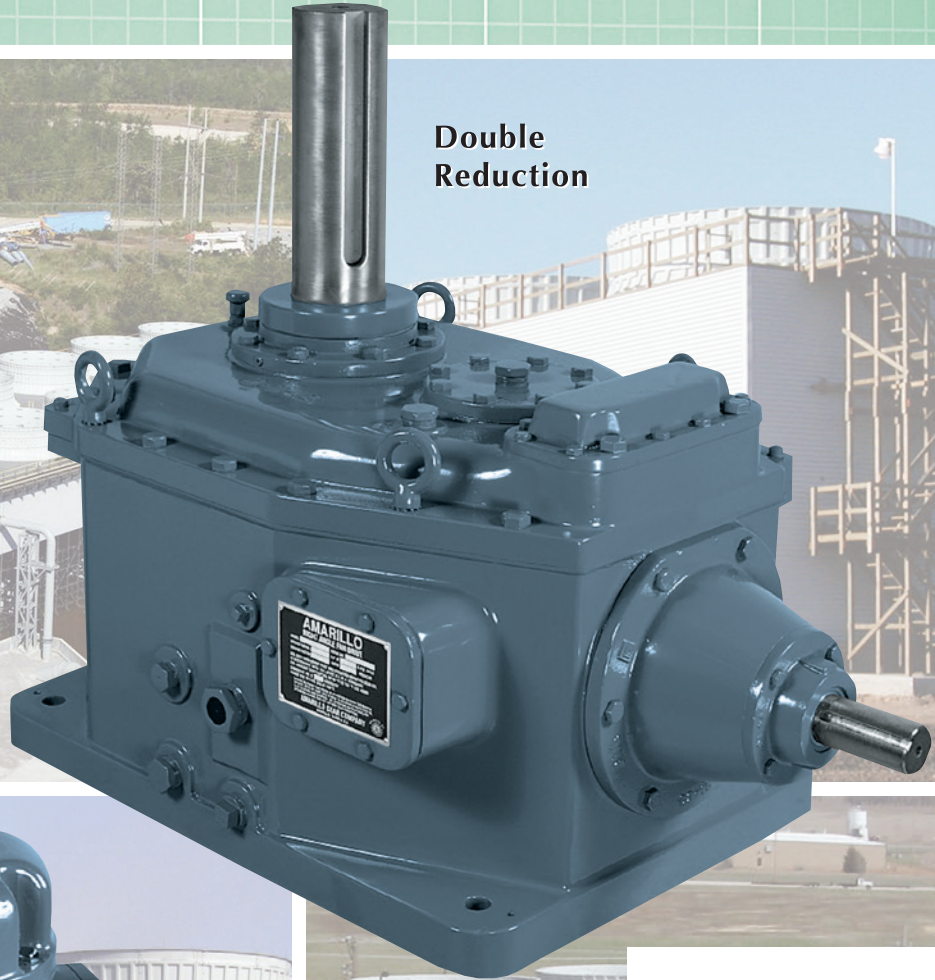

Double Reduction



Single Reduction

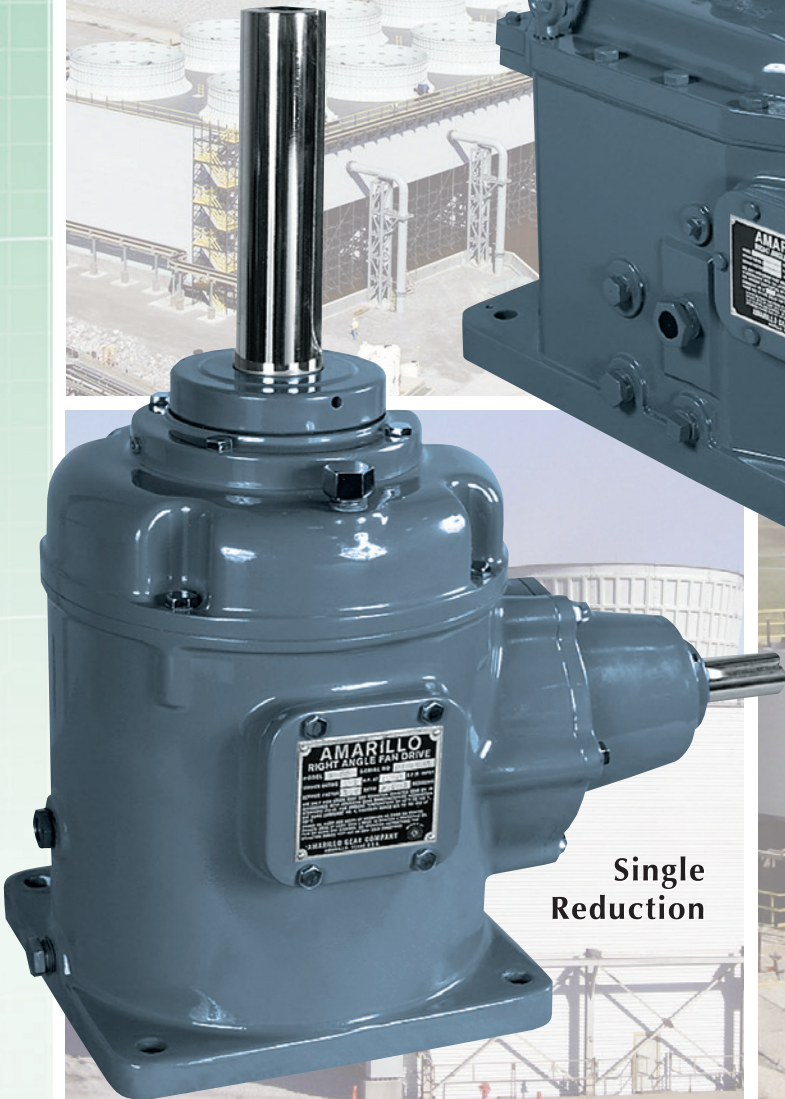

Amarillo[®]
Gear
Company LLC



TABLE I - SINGLE REDUCTION

Service Horsepower Ratings (HP) at (Service Factor = 2.0)																					
Model	Input (RPM)	Ratio* Nominal Ratio (See Table VI for exact ratio)																			
		2.0	2.5	3.0	3.25	3.5	3.75	4.0	4.25	4.5	4.75	5.0	5.5	6.0	6.5	7.0	7.5	8.0	8.5	9.0	9.5
65	1750	25	25	20	18	17		15		12		10									
	1450	21	21	17	15	14		12		10		8									
	1160	17	17	13	12	11		10		8		7									
85	1750		48	45	43	39	36	33	32	28	27	25	20	18	15	15					
	1450		40	37	36	32	30	27	26	23	22	21	17	15	12	12					
	1160		32	30	29	26	24	22	21	19	18	17	13	12	10	10					
110	1750					75	74	72	71	69	64	60	46	40	33	30	25	24			
	1450					62	61	60	59	57	53	50	38	33	27	25	21	20			
	1160					50	49	48	47	46	42	40	30	27	22	20	17	16			
135	1750							110		93	88	83	71	65	59	48	43	42	35	30	
	1450							91		77	73	69	59	54	49	40	36	35	29	25	
	1160							73		62	58	55	47	43	39	32	29	28	23	20	
155	1750											110	100	90	85	75	65	55	50	45	
	1450											91	83	75	70	62	54	46	41	37	
	1160											73	66	60	56	50	43	36	33	30	
175	1750											133	126	112	105	100	80	60	60	60	50
	1450											110	104	93	87	83	66	50	50	50	41
	1160											88	84	74	70	66	53	40	40	40	33

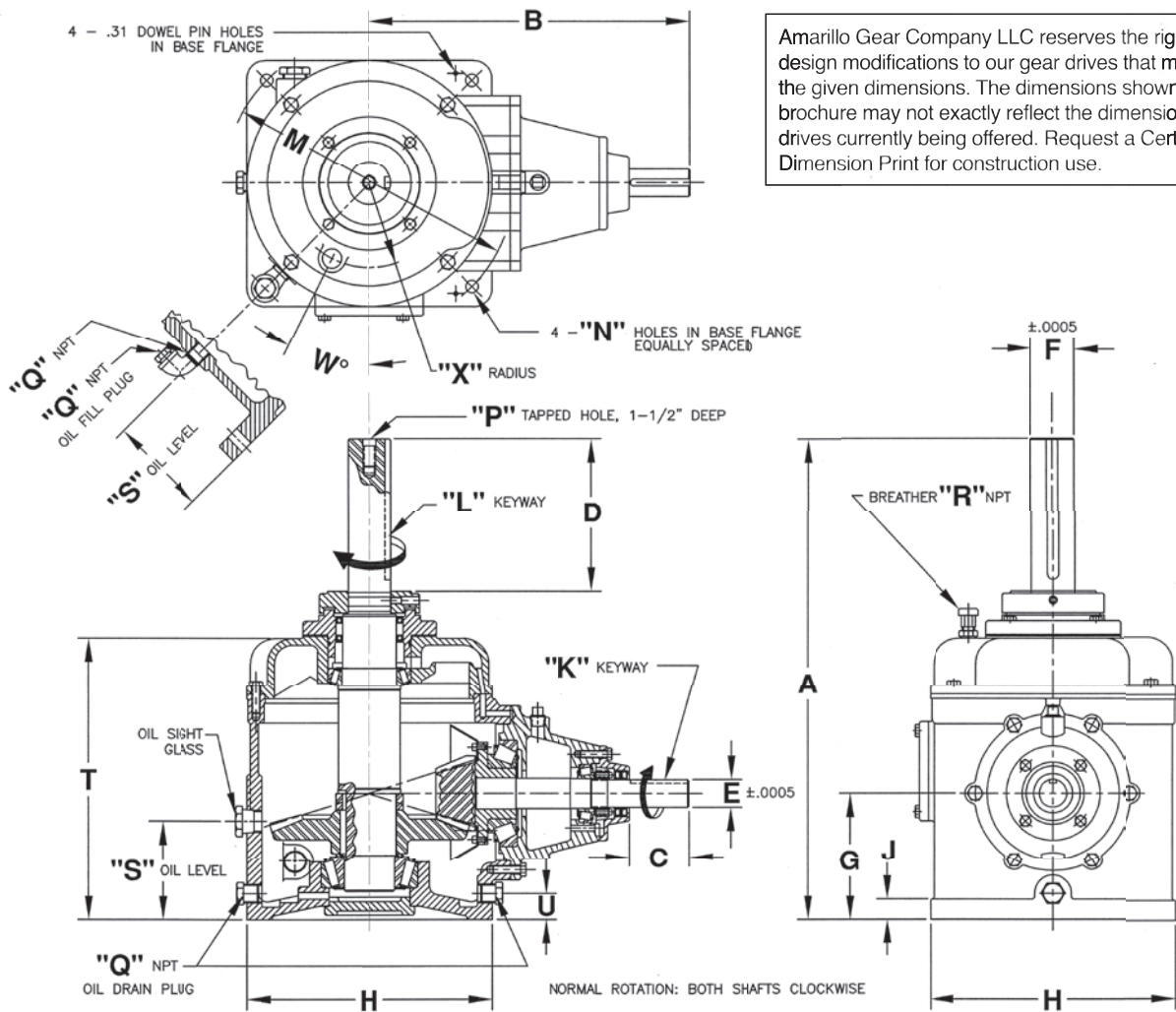

Amarillo Gear Company LLC reserves the right to make design modifications to our gear drives that may change the given dimensions. The dimensions shown in this brochure may not exactly reflect the dimensions of gear drives currently being offered. Request a Certified Dimension Print for construction use.

TABLE II - DIMENSIONS (in)

Model	A	B	C	C with Non-Reverse	D	E	F	G	H	J	K	L	M	N	P	Q	R	S	T	U	W	X	WT/lbs.
* 65	17 ³ / ₈	10 ⁷ / ₈	2 ¹ / ₄	2 ¹ / ₄	6	.999	1.749	5	10	5/8	1/4 X 1/8	3/8 X 3/16	9/8	9/16	3/4 -10NC	1/2	1/2	5	9 1/2	7/8	15	3 1/4	90
85	23 3/4	14 1/4	2 11/16	1 19/32	8	1.249	1.999	6	11	1	5/16 X 5/32	1/2 X 1/4	13	11/16	3/4 -10NC	1/2	1/2	4 9/16	13 3/4	1 3/16	0	4 5/16	195
110	26 1/2	17 5/8	3 5/16	2 1/16	8 1/2	1.499	2.374	7	13 1/2	1 1/8	3/8 X 3/16	5/8 X 5/16	16	11/16	3/4 -10NC	3/4	1/2	5 1/2	15 5/8	1 7/16	0	4 5/8	325
135	29 5/8	21	3 3/4	2 5/16	9	1.874	2.624	8	16	1 1/4	3/8 X 3/16	5/8 X 5/16	20	19/16	3/4 -10NC	3/4	1/2	6	18 5/8	1 3/8	54	5	500
155	31 11/16	23 1/16	3 7/8	2 1/2	9 1/2	1.874	2.999	9 1/2	19	1 1/4	3/8 X 3/16	3/4 X 3/8	22	13/16	3/4 -10NC	3/4	1/2	7	19 3/4	1 3/8	54	6 3/8	675
175	33 3/8	23 1/2	3 9/16	2 1/8	9 1/2	1.874	2.999	9 1/2	20 1/2	1 1/2	3/8 X 3/16	3/4 X 3/8	25	13/16	3/4 -10NC	3/4	1/2	7 1/2	21 1/2	1 1/2	54	7	825

* Model 65 has a 10" Diameter Base



TABLE III - DOUBLE REDUCTION

Service Horsepower Ratings (HP) at (Service Factor = 2.0)																				
Model	Input (RPM)	Ratio* Nominal Ratio (See Table VI for exact ratio)																		
		7.5	8	8.5	9	9.5	10	10.5	11	12	12.5	13	14	15	15.5	16	17	18	19	20
1008	1750	100	100	100	100	95	90	86	82	75		75	60							
	1450	83	83	83	83	79	75	71	68	62		62	50							
	1160	66	66	66	66	63	60	57	54	50		50	40							
1110	1750	142	142	141	140	135	130	130	130	125		125	120							
	1450	118	118	117	116	112	108	108	108	104		104	99							
	1160	94	94	93	93	89	86	86	86	83		83	80							
1311	1750		210	208	206	198	190	183	176	165		160	155	150			137			
	1450		174	172	171	164	157	151	146	137		133	128	124			114			
	1160		139	138	137	131	126	121	117	109		106	103	99			91			
1712	1750				312	300	290	280	271	255	255	241	229	214	207	200	188	178		
	1450				259	249	240	232	225	211	211	200	190	177	171	166	156	147		
	1160				207	198	192	186	180	169	169	160	152	142	137	133	125	118		
1712.5	1750								309	297		279	262	252	244	236	231	225	201	193
	1450								256	246		231	217	209	202	196	191	186	167	160
	1160								205	197		185	174	167	162	156	153	149	133	128
1713	1750								390	343	333	323	310	300	294	285	272	262	250	241
	1450								323	284	276	268	257	249	244	236	225	217	207	200
	1160								259	227	220	214	205	199	195	189	180	174	166	160
1814	1750									454		419	389	363	356	345	324	309	291	279
	1450									376		346	322	301	295	286	268	255	241	231
	1160									301		277	258	241	236	229	215	204	192	184
2016	1750											500	480	460	454	440	420	400	380	360
	1450											414	398	381	376	365	348	331	315	298
	1160											331	318	305	301	292	278	265	252	239

TABLE IV - VERTICAL SHAFT DOWN THRUST CAPACITY (Pounds)

Model	Thrust
65	1500
85	1750
110	2650
135	2500
155	4700
175	5150

Model	Thrust
1008	3800
1110	5400
1311	5950
1311W	12000
1712	8900
1712W	13000
1712.5	9250
1712.5W	13500
1713	10900
1713W	16000
1814	17000
2016	17000

Thrust ratings vary greatly depending upon the transmitted power and the vertical shaft speed. The ratings in TABLE IV are the axial loads that can be applied to the fan shaft which will always result in a calculated bearing life greater than 100,000 hours L₁₀. These ratings are based on the worse case from the power rating tables. Contact the factory when the fan loading conditions or the bearing life requirements cannot be satisfied with the ratings from the tables.

TABLE V - WEIGHTS & SHIPPING DIMENSIONS

Model	Domestic Shipping Weight (lbs)	Weight with Export Crate (lbs)	Export Crate dimensions (in)		
			Length	Width	Height
65A	100	125	15	22	22
85	212	245	16	27	29
110	350	400	20	30	34
135	525	560	24	36	34
155	700	790	30	40	41
175	850	945	30	40	41
1008	875	990	30	40	41
1110	1375	1490	32	49	41
1311	1690	1810	32	49	41
1311W	2025	2265	37	50	49
1712	2125	2210	32	50	44
1712W	2585	2904	41	56	45
1712.5	2400	2550	41	56	45
1712.5W	2860	3179	41	56	45
1713A	2775	2960	41	56	45
1713W	3325	3575	47	56	47
1814	4270	4530	50	65	51
2016	6502	6970	46	70	55

TABLE VI - EXACT RATIO

MODEL	2.0	2.5	3.0	3.25	3.5	3.75	4.0	4.25	4.5	4.75	5.0	5.5	6.0	6.5	7.0	7.5	8.0	8.5	9.0	9.5	
65	2.00	2.47	2.94	3.27	3.54		3.92		4.55		4.90										
85		2.56	3.00	3.23	3.50	3.75	4.00	4.27	4.55	4.70	5.00	5.56	6.00	6.56	7.00						
110				3.46	3.77	4.00	4.25	4.45	4.73	5.00	5.50	6.00	6.56	7.00	7.50	8.00					
135							4.00		4.50	4.73	5.00	5.50	6.00	6.56	7.00	7.50	8.00	8.57	9.00		
155											5.08	5.58	6.00	6.56	7.11	7.56	8.00	8.50	9.00		
175											5.08	5.58	6.09	6.60	7.10	7.56	8.13	8.50	9.14	9.57	

MODEL	7.5	8	8.5	9	9.5	10	10.5	11	12	12.5	13	14	15	15.5	16	17	18	19	20	
1008	7.53	7.97	8.72	8.96	9.64	9.90	10.43	11.08	11.94		12.93	13.93								
1110	7.50	7.96	8.52	8.96	9.35	10.19	10.50	11.05	11.96		12.94	14.06								
1311		8.00	8.72	9.04	9.45	9.90	10.46	11.14	12.16		12.93	13.93	15.13			17.33				
1712				9.04	9.45	9.90	10.55	11.17	12.20	12.50	13.05	13.89	15.00	15.50	16.25	16.86	18.15			
1712.5								11.18	11.85		13.17	13.98	14.69	15.40	15.98	17.21	17.88	19.25	19.83	
1713								11.20	12.27	12.27	13.06	13.83	15.11	15.48	16.17	17.21	18.27	18.58	20.13	
1814									12.06		13.15	14.21	15.23	15.50	16.04	16.88	18.24	18.82	20.02	
2016											13.04	13.86	15.25	15.50	16.05	16.84	17.94	18.67	20.00	

DOUBLE REDUCTION

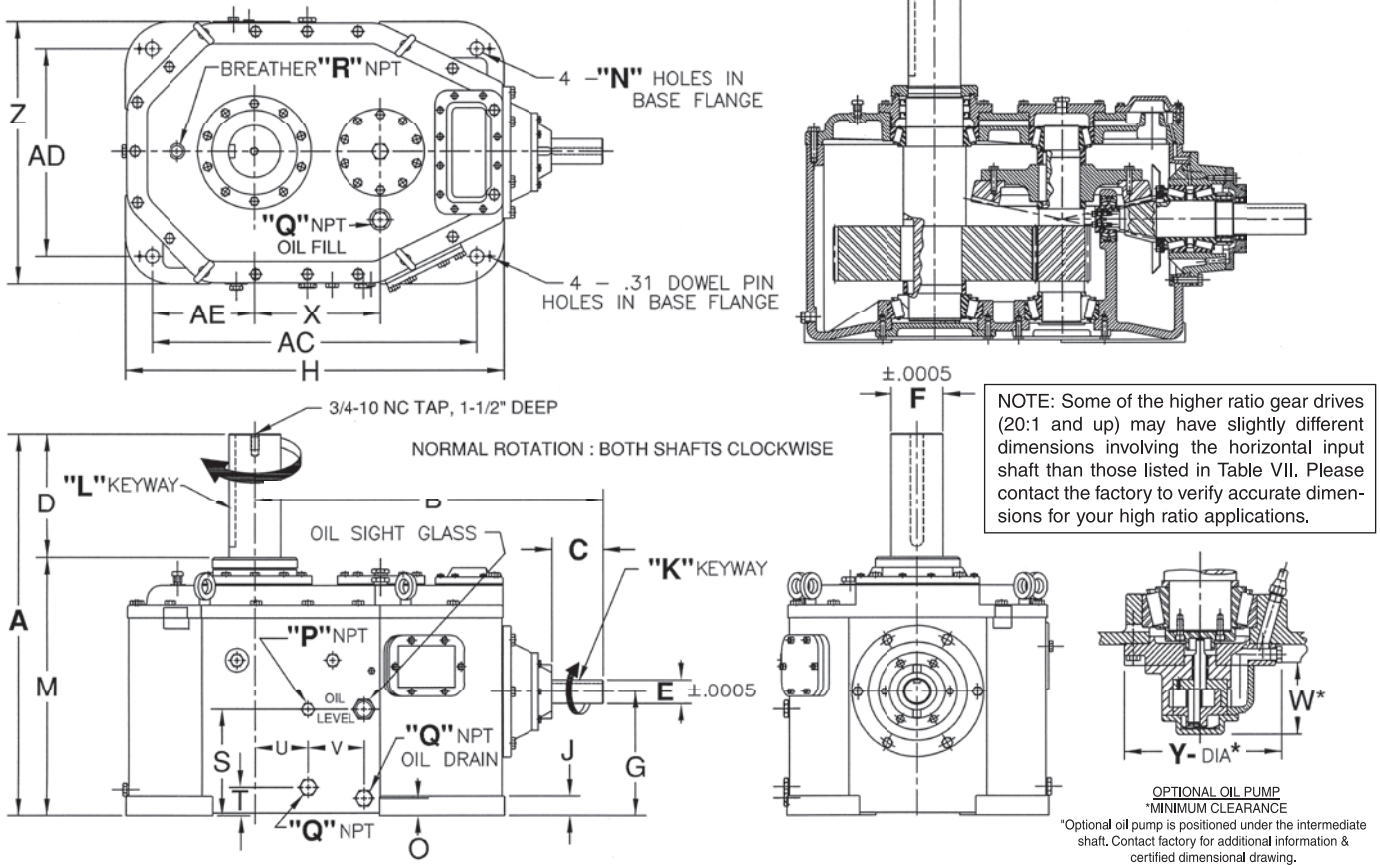

TABLE VII - DIMENSIONS (in)

Model	A	B	C	C with Notch Reverse	D	E	F	G	H	J	K	L	M	N	O
1008	28 1/2	26	3 3/4	2 1/4	10	1.874	3.499	8 1/2	25 1/4	17/8	3/8 x 3/16	7/8 x 7/16	18 1/2	1 1/16	2 1/8
1110	32 5/8	29 3/4	3 3/4	2 1/4	12	1.874	3.999	9 1/2	30 1/4	17/8	3/8 x 3/16	1 x 1/2	20 5/8	1 1/16	2 1/8
1311	34 3/8	30 7/16	4 15/16	3 1/4	12	2.436	4.499	10 1/4	33 1/4	17/8	5/8 x 5/16	1 x 1/2	22 3/8	15/16	1 1/2
1311W*	35 7/8	30 7/16	4 15/16	3 1/4	12	2.436	4.499	11 3/4	33 1/2	1 1/2	5/8 x 5/16	1 x 1/2	23 7/8	15/16	3
1712	35 7/8	33 3/4	4 15/16	3 1/4	12	2.436	4.999	11	36 3/4	17/8	5/8 x 5/16	1 1/4 x 5/8	23 7/8	15/16	1 11/16
1712W*	37 3/8	33 3/4	4 15/16	3 1/4	12	2.436	4.999	12 1/2	37	1 1/2	5/8 x 5/16	1 1/4 x 5/8	25 3/8	15/16	3 3/16
1712.5	36 7/8	35 3/4	5 13/16	3 1/2	12	2.936	4.999	12	36 3/4	17/8	3/4 x 3/8	1 1/4 x 5/8	24 7/8	15/16	1 11/16
1712.5W*	38 3/8	35 3/4	5 13/16	3 1/2	12	2.936	4.999	13 1/2	37	1 1/2	3/4 x 3/8	1 1/4 x 5/8	26 3/8	15/16	3 3/16
1713	38 1/8	37 1/4	5 13/16	3 1/2	12	2.936	5.499	12	40 7/8	1 1/2	3/4 x 3/8	1 1/4 x 5/8	26 1/8	15/16	1 3/4
1713W*	39 5/8	37 1/4	5 13/16	3 1/2	12	2.936	5.499	13 1/2	41	1 1/2	3/4 x 3/8	1 1/4 x 5/8	27 5/8	15/16	3 1/4
1814	44 3/4	39 1/4	5 7/8	5 7/8	15	3.124	6.498	14 1/2	44 1/4	2 1/2	3/4 x 3/8	1 1/2 x 3/4	29 3/4	19/16	2
2016	48 5/8	43 3/4	6	6	15	3.499	7.498	16	52 3/4	3	7/8 x 7/16	1 3/4 x 7/8	33 5/8	1 13/16	2 5/8

Model	P	Q	R	S	T	U	V	W	X	Y	Z	AC	AD	AE	WT/lbs.
1008	3/4	1	1/2	7	2 3/4	1 1/2	3 1/2	2 7/8	8 1/4	10	18 1/2	21 1/4	14 1/2	7 1/4	830
1110	3/4	1	1/2	7	2 3/4	1 3/4	4	2 7/8	10	10	22	26	18	8 7/8	1245
1311	3/4	1	1/2	7 7/8	2 3/4	2 3/4	4	6 13/16	11	10	23 1/2	29 1/4	19 1/2	10 3/8	1575
1311W*	3/4	1	1/2	9 3/8	4 1/4	2 3/4	4	5 5/16	11	10	30	29 1/4	27	10 3/8	1950
1712	3/4	1	1/2	9 1/4	2 3/4	5 1/8	5 1/2	6 3/8	12 1/4	10	25 1/4	31 1/2	20	10	2000
1712W*	3/4	1	1/2	10 3/4	4 1/4	5 1/8	5 1/2	4 7/8	12 1/4	10	32	31 1/2	29	10	2460
1712.5	3/4	1	1/2	10 1/4	2 3/4	5 1/8	5 1/2	6 3/8	12 1/4	10	25 1/4	31 1/2	20	10	2280
1712.5W*	3/4	1	1/2	11 3/4	4 1/4	5 1/8	5 1/2	4 7/8	12 1/4	10	32	31 1/2	29	10	2740
1713	3/4	1	1/2	9 1/4	3 1/4	3 5/8	5 7/16	6 3/8	13 3/4	10 1/2	29 1/4	34 7/8	23 1/4	11 5/8	2600
1713W*	3/4	1	1/2	10 3/4	4 3/4	3 5/8	5 7/16	4 7/8	13 3/4	10 1/2	36	34 7/8	33	11 5/8	3180
1814	3/4	1	1/2	11 1/4	3 3/4	5 1/16	4 7/8	5 5/16	14 1/2	10	31 7/8	37 1/4	24 7/8	12 7/16	3850
2016	3/4	1	1/2	12 1/4	5	5 1/2	8 7/8	5 5/16	16 1/2	10	38 1/4	44 3/4	30 1/4	15 1/8	6390

* The W series incorporates design provisions to counter the very high thrust and undefined loads that are often encountered with applications involving very large fans. Please contact the factory to discuss your applications that might require the W Series gear drives. Dimensions include supplied base plate.

Right Angle Gear Drives For Cooling Towers

The drives Amarillo Gear Company LLC produces for cooling tower and air fin heat exchanger service reflect a long history of quality workmanship and reliability. Amarillo Gear has been designing and manufacturing right angle drives since 1934, and the commitment to excellence continues today. One example of this commitment is the availability of complete noise and vibration testing, with all data taken under full horsepower loading up to 500 hp.

Features

Design features and ratings are in accordance with, or exceed, the minimum requirements of AGMA (American Gear Manufacturers Association) and CTI (Cooling Technology Institute) standards.

Housing and Castings

Castings are rigidly designed and constructed to absorb internal and external loads with minimum deflection. Gear case and cover are manufactured to assure permanent alignment of bearings and gears under load. The sloped floor of the gear case adds rigidity and permits complete oil drainage. All casting materials are gray cast iron for effective damping of noise and vibration. All mating castings are sealed using "formed-in-place" gasket material that eliminates "weeping" associated with fiber-type gaskets. Gear cases are pre-drilled with pilot holes to assist in installation of dowel pins.

Spiral Bevel Gears

Designed and manufactured by Amarillo Gear Company LLC for fan drive service. All spiral bevel gears are precision machined from high grade alloy steel, case hardened and lapped in pairs.

Helical Gears

Helical gears are designed specifically for fan drive service and are precision machined from high grade alloy steel, case hardened and precision ground to provide low-noise, low vibration operation.

Bearings

Amarillo Gear is an industry leader with L_{10a} bearing life exceeding 100,000 hours on all bearings. Input and intermediate bearings provide double the service life specified in AGMA and CTI standards, resulting in lower maintenance costs. The fan shaft bearings are designed to carry all loads imposed by the fan while maintaining this outstanding bearing life. Only trusted name brand bearings such as Timken and SKF are installed in Amarillo fan drives.

Quiet Operation

Quiet operation of the Amarillo Fan Drives is achieved through careful design and controlled manufacturing methods of components. Our engineers understand all of the many parameters that affect gear noise and have applied the latest research to the design and manufacture of all components. Parameters that reduce gear noise are controlled during design, manufacturing, and assembly to ensure quiet operation. Rigid shafts and permanently aligned housings guarantee alignment of gears under load. Test results collected in our state-of-the-art test facility prove that our sound levels are the lowest available in the industry.

Shafting

Amply sized to provide a rugged spindle for the fan. Surfaces for gears, bearings, input coupling and fan hub are precision machined.

Shaft Seals

Both the input and output shaft openings have 2 spring-loaded, single-lip seals to keep outside contamination from entering the gearbox. Plus, the output shaft has a labyrinth-type plate directly mounted to the shaft to triple protect the gearbox from contamination that might try to enter due to the natural effect of gravitation.

Lubrication

Oversized slinger on the input shaft provides excellent lubrication in either direction or at half speed operation. Continuous circulation of oil to all bearings is assured by location of adequately sized channels and baffles. Double reduction units can also be supplied with a positive displacement bi-directional oil pump/internal oil distribution system. This pump is driven from the intermediate shaft and provides a redundant lubrication system for extreme reliability. A permanently mounted oil sight glass is provided on all units to provide direct visual determination of oil level.

Fan drives ship with the first fill of operating mineral oil installed. Synthetic oil is also available as an option. Synthetic lubricants offer advantages of extended service life, a broader operational temperature range, reduced friction, and the ability to maintain a higher film strength which can extend the service life of the gear drive.

Low Speed Operation

For operation when motor speeds are less than 450 rpm, single reduction fan drives require Amarillo Gear's exclusive "Low Speed" option, and double reduction fan drives require a mechanical oil pump for proper lubrication. The addition of these options allow operation with no minimum input speed restrictions.

Service Openings

Large inspection opening facilitates periodic inspections. Ports for oil fill, oil drain and venting are tapped and located for installation of remote service piping when desired.

Optional Features

Special output shaft extensions, backstops (anti-windmilling), oil level switches, oil heaters & thermostats, oil temperature gauges, spot-face/drill & tap for vibration transducers, "low speed" option, and other accessory items are available on special order

Catalog CT 08/15



Amarillo® Gear Company LLC

Post Office Box 1789 • Amarillo, Texas 79105 • 2401 Sundown Lane (79118) 806•622•1273 • FAX 806•622•3258
www.amarillogear.com e-mail: info@amarillogear.com © AGC 2015



A Marmon Water/Berkshire Hathaway Company

Each Amarillo Gear fan drive is the result of careful design and manufacturing technique. As with any precision machine component, proper selection, installation, maintenance and operating procedures are imperative for long life and trouble-free service. The following instructions are offered for selection of gear drives for usual applications. Our engineers will be pleased to assist when unusual conditions require special procedures.

Selection

The required ratio is established by dividing the input or driver speed by the output or fan speed. Select the ratio from the table that is the closest to the required ratio. Select a gear drive from the table that has a service rating listed under the required ratio column that is equal to or greater than the power rating of the driver at the input speed. When gear drives are to be selected using a service factor other than 2.0, multiply the "service rating" from the tables by 2.0 to get the "mechanical rating." The "mechanical rating" is then divided by the appropriate service factor to obtain the new "service rating" at the required service factor. Efficiency varies with speed, power and thrust, with normal ranges between 95-98%. Contact factory for actual values for your application.

Ratio

All ratios are reducing and defined as the ratio of input speed to output speed. Single reduction ratios shown in Table I are exact within $\pm 2\%$. Double reduction ratios shown in Table III are exact within $\pm 3\%$.

Ratings

AGMA and CTI recommend a minimum service factor of 2.0 for gear drives in cooling tower fan service when driven by electric motors or steam turbines. All ratings in Table I and Table III are service ratings and include a 2.0 service factor. Ratings are listed for both 60 and 50 cycle electric motor speeds. Ratings at intermediate speeds may be interpolated from the tables. Contact the factory for recommendations when the driver speed exceeds 1800 rpm.

Thermal Rating

The thermal ratings of Amarillo Gear cooling tower drives are equal to or exceed the service ratings listed in Tables I & III when the discharge air temperature is 120°F or less. Contact the factory for thermal rating when the air temperature exceeds 120°F.

Direction of Rotation

Normal rotation is both shafts clockwise as shown in the illustrations. Occasional use with both shafts rotating counterclockwise is permissible.

"W" Series

The "W" Series of gear drives were developed primarily for applications involving larger diameter fans. These applications may require special design features to be incorporated in the gear drives to accommodate the higher thrust and undefined dynamic loads which are normally associated with larger diameter fans. Contact Amarillo Gear to discuss any applications involving 36 foot or larger diameter fans.

To view Amarillo's complete warranty terms, please visit www.amarillogear.com

