

MERIDIAN: "The highest point or stage of development; peak"



MERIDIAN[®] SERIES COOLING TOWERS



The convenience of packaged.
The longevity of fiberglass.

MERIDIAN

A meridian is a peak, the highest point or stage of development, and EvapTech's Meridian® series lives up to its name.

OVERVIEW

Packaged steel is cheap and fast but doesn't last. Field-erected FRP is long lasting and energy efficient but costly and slow. That's where the Meridian® comes in—an industrial-scale, fiberglass-framed, modular cooling tower.

Unlike competing products, the Meridian® series maintains the superior thermal performance and longevity of fiberglass while reducing lead time and site assembly time by 50% or more. This innovative design is primarily factory-assembled into modules prior to shipment, reducing the number of parts that need site assembly and laydown area compared to standard field-erected towers. The result? Faster installation, **greater site safety** and far better value over the lifetime of the product.



INDUSTRIES

- ▶ DATA CENTERS
- ▶ INDUSTRIAL PROCESS
- ▶ AIRPORTS
- ▶ UNIVERSITIES
- ▶ HOSPITALS

THE MERIDIAN® SERIES

EC MERIDIAN® (ECM)

The base Meridian® features a pressurized water distribution system, PVC fill, high-efficiency eliminators, water and sight tight (WST™) louvers, premium mechanical equipment, basin flexibility, and easy maintenance access.

With the ECM, you can customize the fill and louvers to meet project-specific thermal and water quality compliance needs. The entire Meridian® series is available in a range of single-cell sizes and fully capable of being installed in a multi-cell arrangement to meet a variety of applications.

FM APPROVED—ES PRIME MERIDIAN® (ESPM)

Fortified with Factory Mutual Approved features, this model eliminates the need for a fire protection system and keeps equipment operational after a fire, hurricane, tornado or seismic event. Take advantage of lower insurance premiums and have comfort knowing the ESPM is a high-quality product that has undergone the rigors of FM Approvals testing.

Modifications for the ESPM include substituting zero flame spread Franklin™ Fill, special drift eliminators, hardened casing and fan cylinders.

PACKAGED STEEL (Galvanized or Stainless)
Lasts 15-20 Years (20+ for Stainless)
6-10 Weeks Lead Time, Days to Install
Low Energy Efficiency & Limited Capacity

MERIDIAN® SERIES
Lasts 30+ Years
12-16 Weeks Lead Time, Days to Install
High Energy Efficiency & Moderately Scalable

FIELD-ERECTED FRP
Lasts 30+ Years
22-26 Weeks Lead Time, Weeks/Months to Install
High Energy Efficiency & Highly Scalable

PRESSURIZED WATER DISTRIBUTION SYSTEM

- Exterior manifold maintains a single connection per cell while assuring reliable connection between modules
- Identical systems across modules ensure even water distribution and peak thermal performance
- Fiberglass external header assures long life

CUSTOM FILL & HIGH-EFFICIENCY ELIMINATORS

- Bottom-supported, single pack height, PVC fill media greatly enhances structural integrity and reduces fouling
- Customize fill for alternate water qualities (high efficiency, low/no fouling, SplashPack™)
- DriAir™ 80 drift eliminators limit drift rate to <0.0005% of the circulating water flow

WATER AND SIGHT TIGHT (WST™) LOUVERS

- Removable for basin access
- Sight-tight design keeps sunlight out, preventing biological growth
- Keeps water in while keeping dirt and debris out
- Blade type louvers optional

PREMIUM MECHANICAL EQUIPMENT

- Only the best brands chosen for fans, gearboxes, driveshafts, motors and more
- Go-to suppliers include EvapTech and Hudson fans, Amarillo gears and Addax Rexnord driveshafts
- Same components used in our industry-leading counterflow and crossflow towers for 15+ years

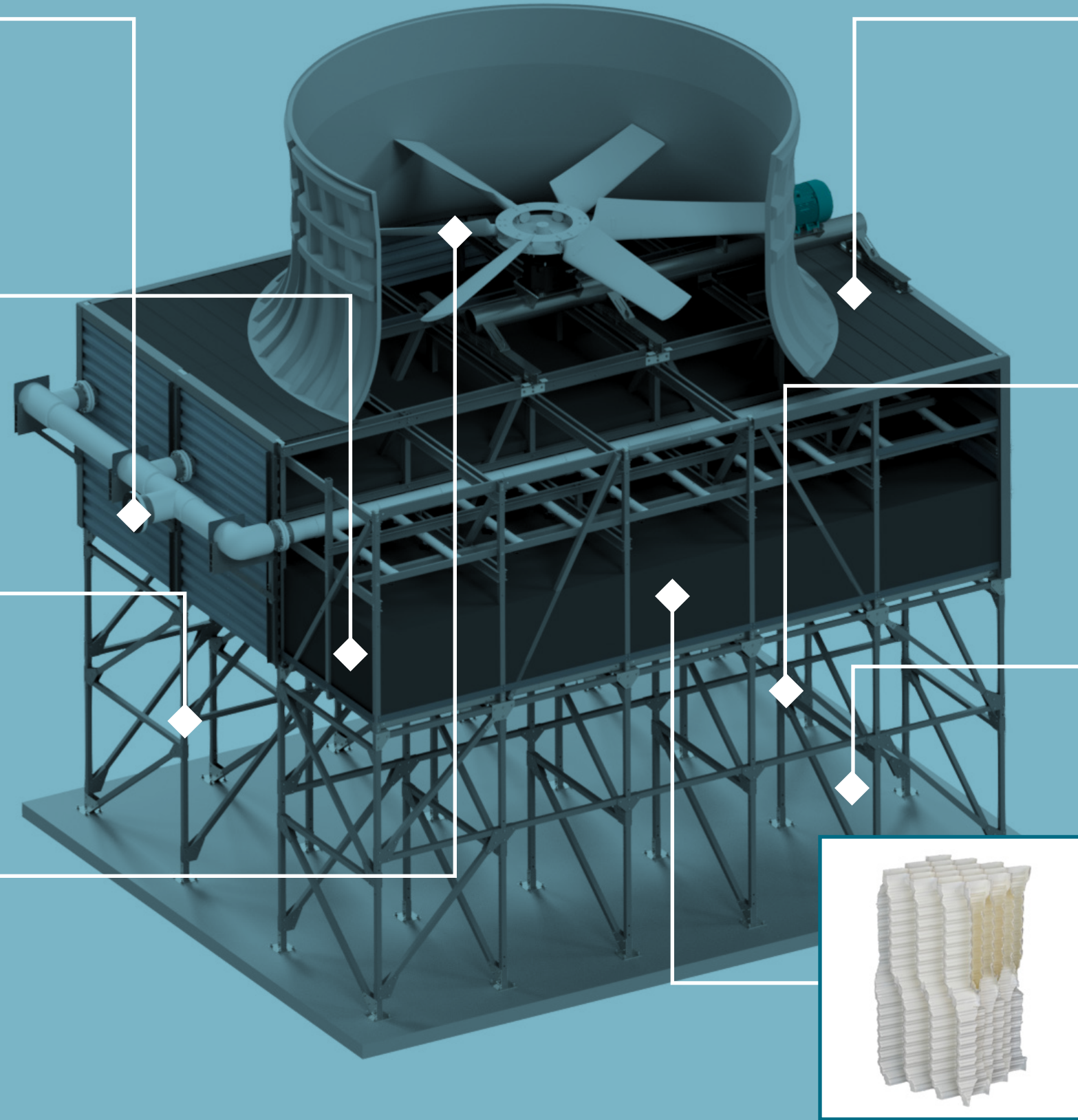

EASY MAINTENANCE ACCESS

- Access equipment via the EvapStack™ door, fan deck ladder and elevated fan deck tie-off
- Integrated, patent-pending, elevated engineering tie-off point in each fan cylinder segment
- Optional louver access door for easy basin inspection
- Optional internal ladder and grated walkway for access to inner components
- Optional fan deck handrails

FRP-FRAMED MODULES & LEG SETS

- Fiberglass frame provides high corrosion resistance compared to steel modular options
- Structure designed to meet the most stringent of wind and seismic loads
- Lightweight structure provides for safer onsite installation

BASIN FLEXIBILITY

- Tower optimally installed on new or existing concrete basins
- Fiberglass or stainless steel basins also available

OPTIONAL FM APPROVED FEATURES

- Eliminates the need for a fire protection system
- Keeps equipment operational after a fire, hurricane, tornado or seismic event
- Zero flame spread Franklin™ Fill and drift eliminators
- Safewall™ hardened casing system



1 or 2 Cell Towers

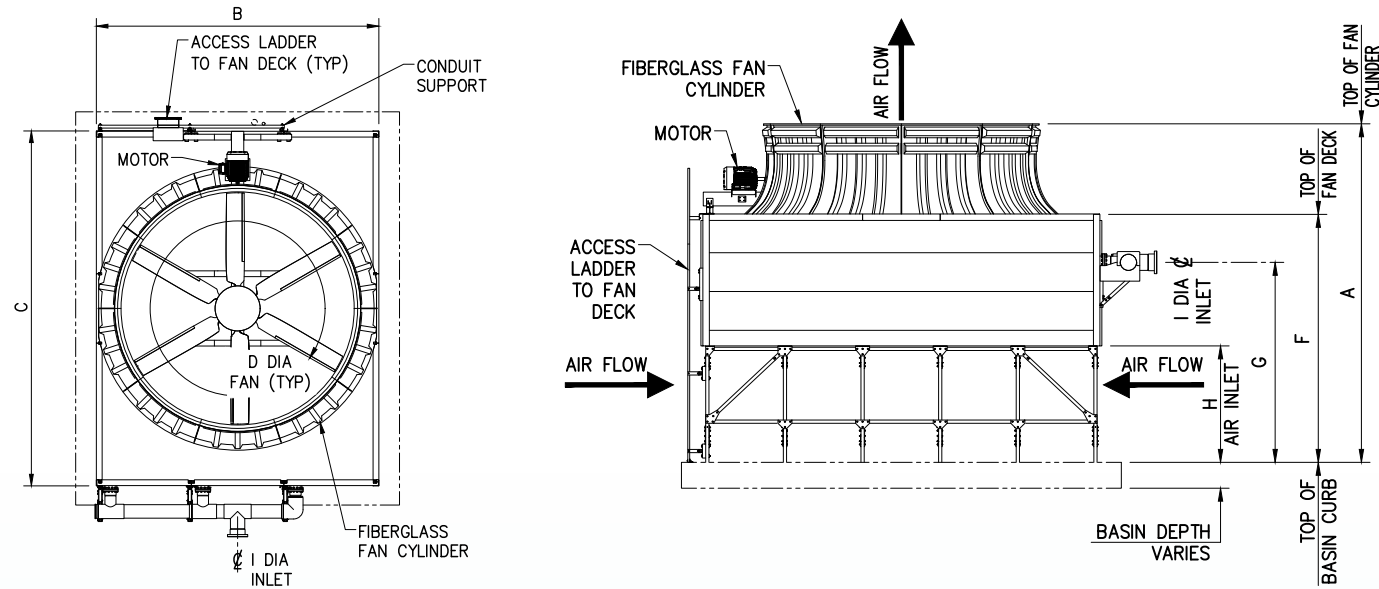

Model No.	Nominal Tonnage per Cell	Fan Motor (HP/Cell)	Overall Height (A)	Nom Cell Length (B)	Nom Cell Width (C)	Fan Diameter (D)	Deck Height (E)	Inlet Height (F)	Air Inlet Height (G)	Inlet Dia (H)	Approx. Weights (LBS) per Cell excl. Basin	
											Operating	Heaviest
ECM"X"24-424J	1,427	60	23.2	24	24	18	16.2	12.4	6	16	31,000	5,000
ECM"X"24-424K	1,536	75										
ECM"X"24-424M	1,672	100										
ECM"X"30-424J	1,641	60	23.2	24	30	20	16.2	12.4	6	16	39,000	5,900
ECM"X"30-424K	1,767	75										
ECM"X"30-424M	1,937	100										
ECM"X"30-432K	2,078	75	23.2	32	30	22	16.2	12.4	6	20	52,000	5,900
ECM"X"30-432M	2,300	100										
ECM"X"30-432N	2,467	125										
ECM"X"36-432M	2,707	100	28.2	32	36	26	18.2	14.4	8	20	64,000	7,000
ECM"X"36-432N	2,890	125										
ECM"X"36-432P	3,057	150										
ECM"X"36-440P	3,597	150	28.2	40	36	28	18.2	14.4	8	20	79,000	7,000

ECM - Standard Model
 ESPM - FM Approved Model
 "X" - Indicates number of cells in tower
 Contact EvapTech Representative for detailed layout drawings including 2 cell and custom arrangements.

3+ Cell Towers

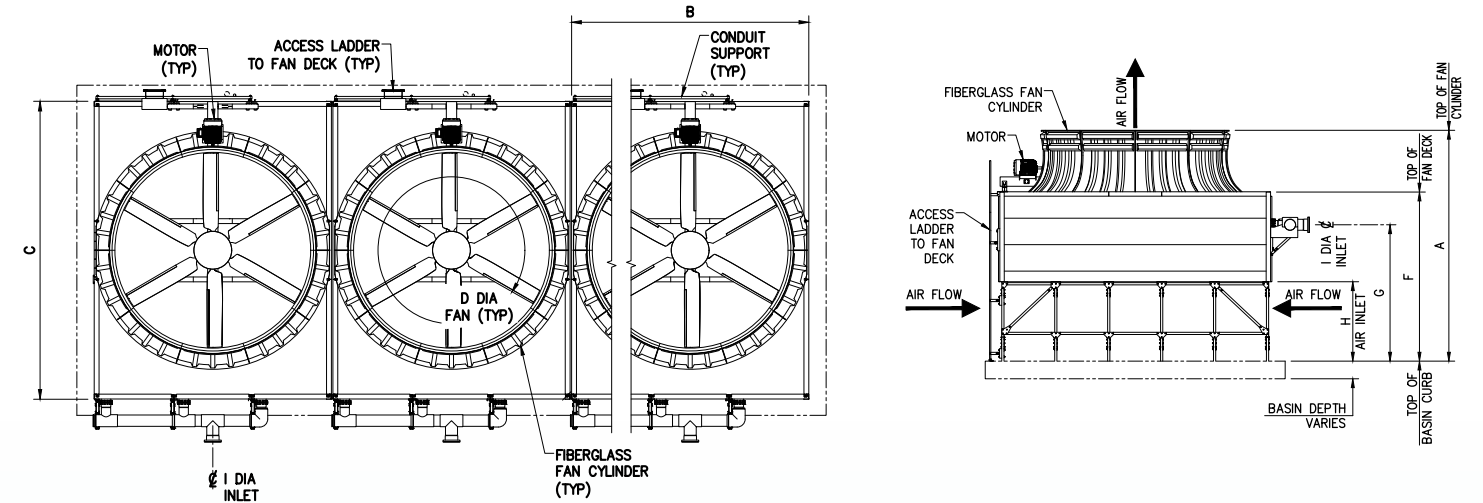

Model No.	Nominal Tonnage per Cell	Fan Motor (HP/Cell)	Overall Height (A)	Nom Cell Length (B)	Nom Cell Width (C)	Fan Diameter (D)	Deck Height (E)	Inlet Height (F)	Air Inlet Height (G)	Inlet Dia (H)	Approx. Weights (LBS) per Cell excl. Basin	
											Operating	Heaviest
ECM"X"24-424J	1,429	60	26.2	24	24	18	19.2	15.4	9	16	31,000	5,000
ECM"X"24-424K	1,537	75										
ECM"X"24-424M	1,672	100										
ECM"X"30-424J	1,630	60	26.2	24	30	20	19.2	15.4	9	16	39,000	5,900
ECM"X"30-424K	1,756	75										
ECM"X"30-424M	1,922	100										
ECM"X"30-432K	2,083	75	26.2	32	30	22	19.2	15.4	9	20	52,000	5,900
ECM"X"30-432M	2,308	100										
ECM"X"30-432N	2,473	125										
ECM"X"36-432M	2,667	100	31.2	32	36	26	21.2	17.4	11	20	64,000	7,000
ECM"X"36-432N	2,881	125										
ECM"X"36-432P	3,016	150										
ECM"X"36-440P	3,578	150	31.2	40	36	28	21.2	17.4	11	20	79,000	7,000

ECM - Standard Model
 ESPM - FM Approved Model
 "X" - Indicates number of cells in tower
 Contact EvapTech Representative for detailed layout drawings including custom arrangements.



- ★ EVAPCO World HQ R&D Center
- ☆ EvapTech HQ
- EVAPCO Facilities
- EvapTech Facilities

About EvapTech®

Learn More & Get Started

EvapTech is a premier cooling tower designer, manufacturer and contractor providing Research-Powered Solutions for the power generation, industrial, refrigeration and HVAC evaporative cooling markets.

A wholly owned subsidiary of EVAPCO, Inc., we are the only supplier to have complete control and ownership of the structure, heat transfer media, eliminator and water distribution components. This makes for high-quality products that perform exactly as specified and promised—all with superior thermal capability.

